



# CDI CUSTOM CURB ADAPTERS

## VIBRATION ISOLATION CURB

CDI'S "ISO CURB" INCORPORATES THE LATEST IN DESIGN AND INNOVATION for the HVAC market utilizing adjustable isolators in a single piece curb system. CDI Curb systems may be fully installed and roofed in prior to mounting RTU/AHU minimizing unaccounted labor time and delays with other "field assembly required" curbs on the market. Prime G-90 18ga weather skirting and bulb style weather seal provide a long lasting solution to the cracking and failing of "other" exposed rubber weather seal designs. All curb systems are subjected to SolidWorks Simulation load testing prior to fabrication accommodating RTU/AHU and all accessories weight and center of gravity insuring a minimum 90% isolation efficiency.

— ONE PIECE CONSTRUCTION / same great CDI lead times apply —

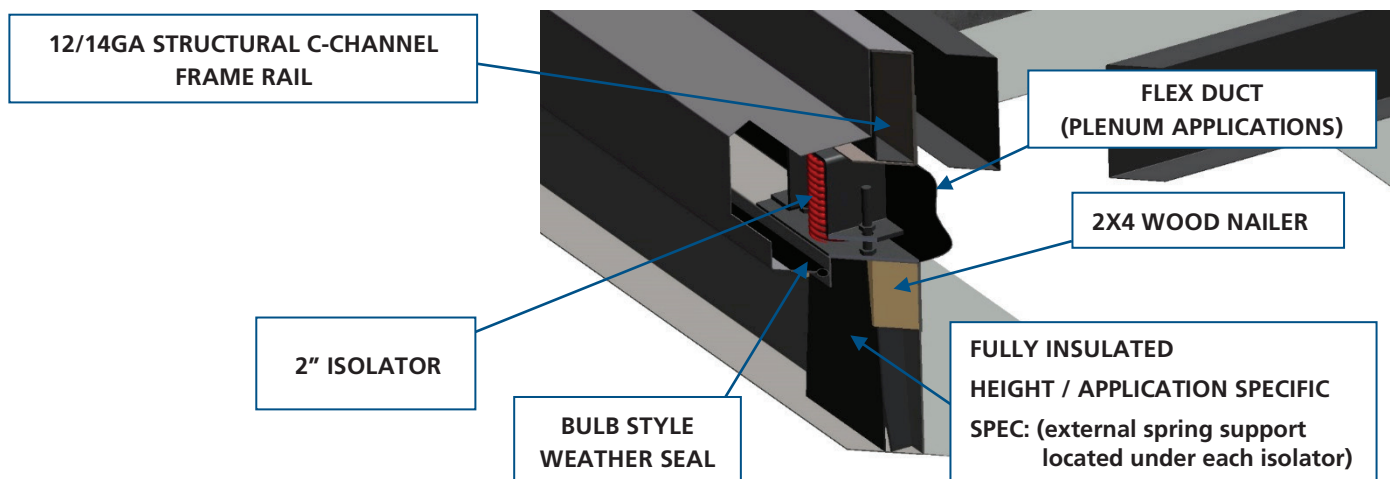
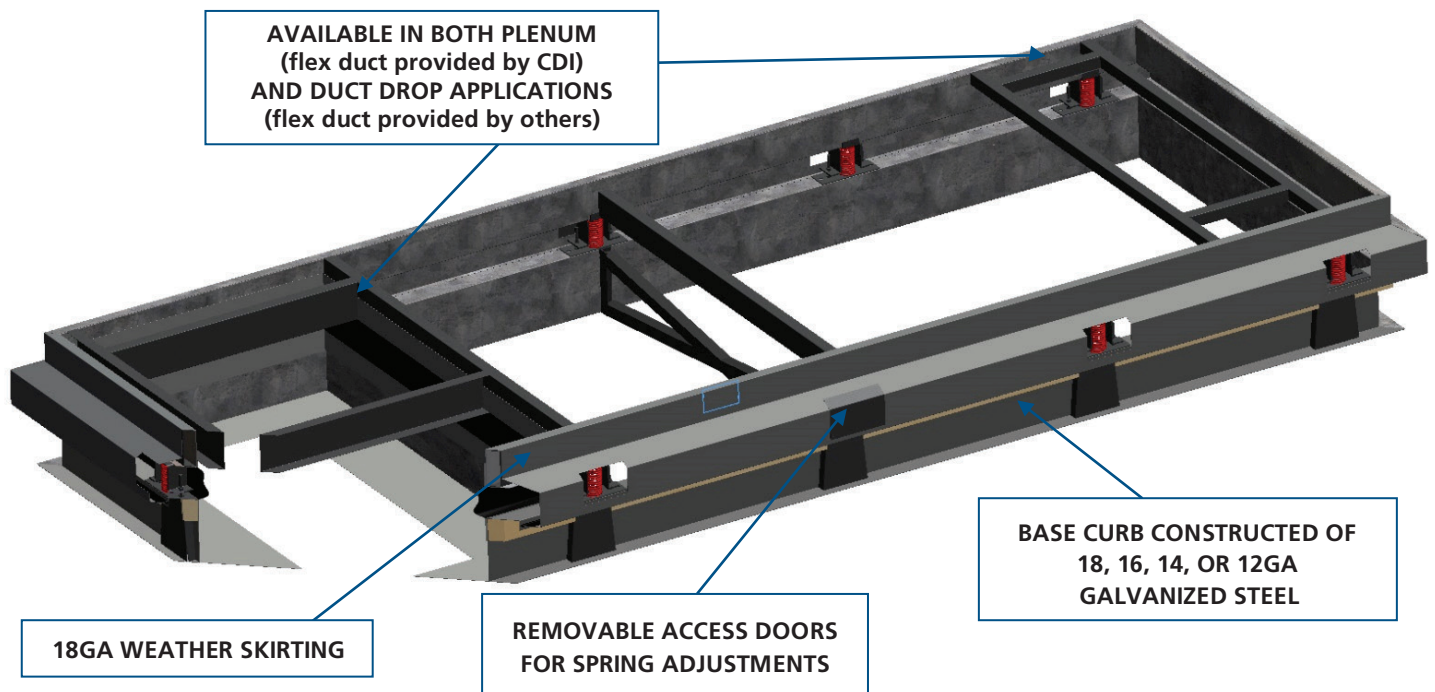

## VIBRATION ISOLATION CURB

### STANDARD CONSTRUCTION DETAILS

1. Minimum overall height 18"
2. 2" Spring deflection
3. 2x4 wood nailer provided
4. 18-12ga Prime G-90 galvanized steel
5. Fully welded and mitered seams and corners
6. Weather skirt and bulb seal insure water tight seal
7. 2" minimum base flange for securing to building
8. Acoustically non-conductive materials minimize sound transitions
9. Stabilizing Isolators eliminate excess movement
10. Removable Access doors for spring isolator field adjustment
11. Same great CDI lead times apply

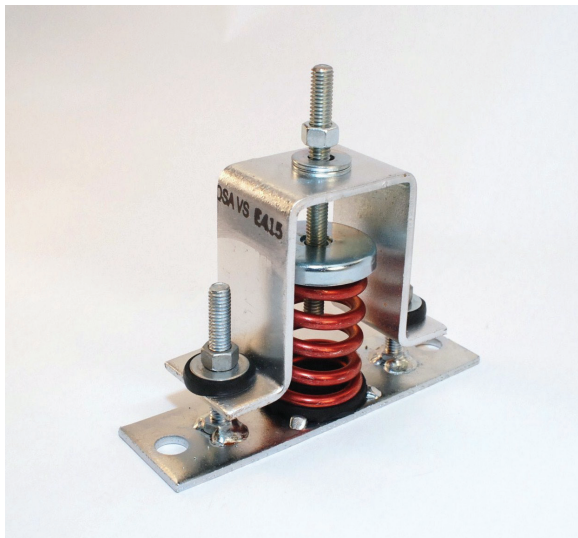

### ISOLATOR SPEC

1. Housings Hot Dip Galvanized (HDG)
2. Hardware Zinc Plate
3. Springs Powder Coated or Zinc Plated
4. 2" Deflection
5. Style K Load Transfer Nut is pinned to stud
6. Large diameter springs with O.D. not less than 80% of rated deflection height
7. For compact support of heavy loads, some include inner springs
8. California Pre-Approved seismic protection OPA-0070

### CURB SPECIFICATIONS

Vibration Isolation curb systems are manufactured of 12-18ga (ASTM A653/653M) prime G90 galvanized steel construction. All corners and seams are mitered and fully welded with internal 12ga/A.I. structural cross and vertical supports when necessary. All curb systems are water tight and plenum applications are air tight utilizing internal flex duct. Top of all Vibration isolation curb systems are level with pitches built into curb when deck slopes. Vibration isolation curb systems are designed to provide a minimum of 90% isolation efficiency with 2" deflection.

**CDIcurbs.com** ■ 1-888-234-7001

**CONTACT** ► CDI Sales Rep for pricing and availability

**PROUDLY MADE IN AMERICA** ■ CHARLOTTE ■ DALLAS ■ MINNEAPOLIS ■ PHOENIX ■ SEATTLE